

V20 TE2

670 kW@1500 rpm

740 kW@1800 rpm

EPA/CARB TIER 2

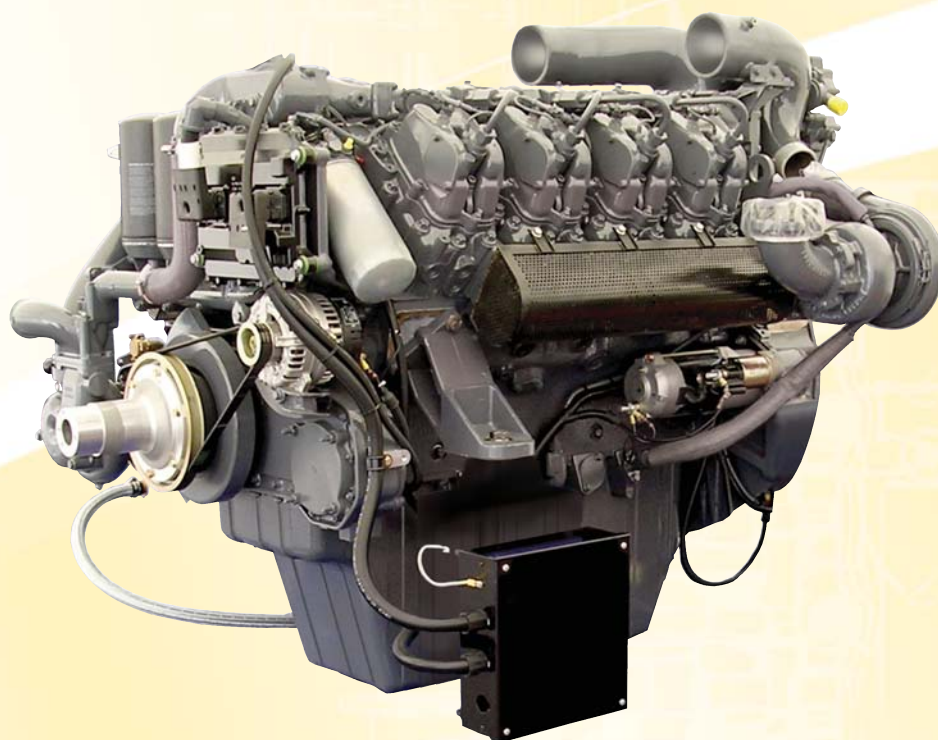

**ENGINE FOR
POWER GENERATION
APPLICATIONS**

V20 TE2 FOR POWER GENERATION APPLICATIONS

Specifications

Thermodynamic cycle		Diesel, 4 stroke, D.I.	
Air intake		TAA	
Arrangement		8, V configuration	
Bore x stroke	mm (in)	145x152 (5.71 x 5.98)	
Total displacement	l	20	
Valves per cylinder		4	
Injection system		electronic Common Rail	
Speed governor		electronic	
Cooling system		liquid (water + 50% Paraflu11)	
Flywheel housing/flywheel	type	SAE0 / 18"	
Flywheel rotation		CCW	
Lube oil specifications		ACEA E3-E5	
Lube oil consumption		<0.1% of fuel consumption	
Fuel specifications		EN 590	
Oil and filters intervals for replacement	hours	1000	
Fuel consumption at:	rpm	1500	1800
	100% load l/h (g/kWh)	148 (192)	171 (206)
	80% load l/h (g/kWh)	113 (203)	130 (210)
	50% load l/h (g/kWh)	78 (210)	90 (218)
Coolant capacity: engine only	l	~35	
	engine+radiator	l	~85
ATB (without canopy)	°C (°F)	50 (122)	
No remote cooling radiator allowed			
Lube oil total system capacity including pipes, filters etc.	l	~85	
Electrical system		24Vcc	
Starting batteries: recommended capacity	Ah	2x220	
Discharge current (EN 50342)	A	1200	
Cold starting:	without air preheating	°C (°F) -10 (14)	
	with air preheating	°C (°F) -25 (-13)	

Performance

Ratings ¹		1500 rpm		1800 rpm	
		PRIME	STAND-BY	PRIME	STAND-BY
Rated Output ²	kW/m	609	670	673	740

1) Ratings in accordance with ISO 8528. For duty at temperature over 40°C and/or altitude over 1000 meters must be considered a power derating factor. Contact the FPT sales organization

2) Net power at flywheel available after 50 hours running with a ±3% tolerance; EPA TIER 2

PRIME POWER: The prime power is the maximum power available with varying loads for an unlimited number of hours. The average power output during a 24h period of operation must not exceed 80% of the declared prime power between the prescribed maintenance intervals and at standard environmental conditions. A 10% overload is permissible for 1 hour every 12 hours of operation.

STAND-BY POWER: The stand-by power is the maximum power available for a period of 500 hours/year with a mean factor of 90% of the declared stand-by power. No kind of overloads is permissible for this use.

CONTINUOUS POWER: Contact the FPT sales organization.

V20 TE2 FOR POWER GENERATION APPLICATIONS

Standard Configuration:

FPT engine V20 TE2 equipped with:

- Loose/radiator incorporated air-to-air charge cooler
- Front radiator guard
- Oil drain pump
- Mounted belt driven pusher fan
- Fan guard
- Primary fuel filter/water separator
- Replaceable oil filter
- Electronic engine control unit with wiring loom and sensors
- Box relays
- WT and OP sensors
- Low water level sensor
- Front engine mounting brackets
- Flywheel housing SAE0 and flywheel 18
- Re-directable exhaust gas elbow
- Oil dipstick
- 24Vdc electrical system
- User's handbook

THE ENGINE IS SUPPLIED WITHOUT LIQUIDS

Optional equipment:

On request the engine can be supplied with:

- 230 Volt water jacket heater
- WT and OP sensors for gauges
- Turbo and exhaust gas guards
- Exhaust gas flexible joint

Overall dimensions

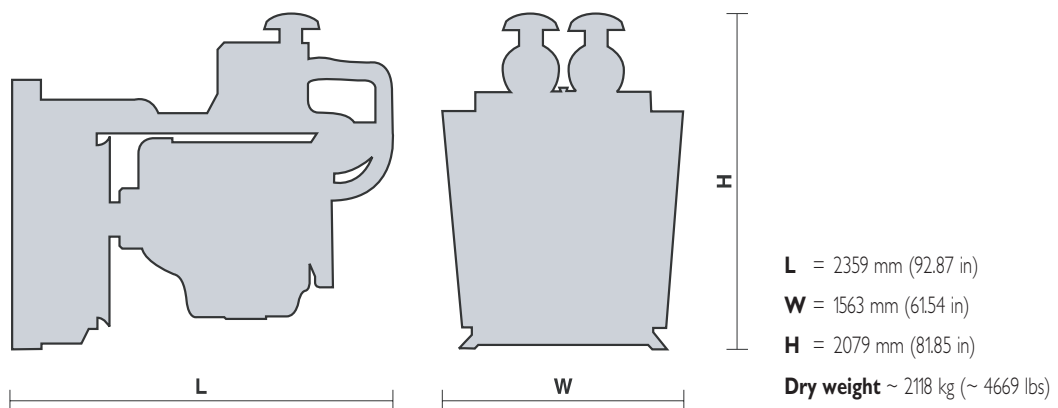

ENGINE BENEFITS

- **PERFORMANCE:** Compact packaging; starting temperature as low as 14 °F (-10 °C) without starting aids; performance achieved without external EGR; very compact 2nd generation common rail system (2 rails); consistent performance up to 104°F (40°C) and 3281 ft (1000 m) a.s.l.; engine changeable to 1500 or 1800 rpm; load acceptance according to G3 class (ISO 8528-5)
- **SERVICEABILITY:** Worldwide service network
- **COST EFFECTIVENESS:** New extended 1000 h maintenance intervals (oil and filters change); reduced oil and fuel consumption
- **ENVIRONMENTALLY FRIENDLY:** Reduced noise; emission legislation compliance
- **CUSTOMER ORIENTATION:** Standard generator interface SAE0

FIAT POWERTRAIN TECHNOLOGIES

Via Puglia, 15 - 10156 Torino

FIAT POWERTRAIN TECHNOLOGIES

Viale dell'Industria, 15/17 - 20010 Pregnana Milanese (MI)

www.ftpowertrain.com

LOCAL DISTRIBUTOR